



**Electric Part-turn Lever Actuators
with a Constant Output Speed**

**MODACT MPS, MPSP
MODACT MPS, MPSP CONTROL**

Type numbers 52 260 - 52 266



www.zpa-pecky.cz

ZPA Pečky, a.s. is certified company in accordance with ISO 9001 as amended.

1. APPLICATION

The **MODACT MPS** and **MPSP** electric part-turn (*lever*) actuators operating at a constant speed are used for remote control and automatic regulation of flaps, louvers and valves and to control the regulation members of the heating and air-conditioning or other devices, for which they are suitable with their characteristics. The **MODACT MPS** and **MPSP Control** actuators are designed for use in automatic control systems employing a continuous control signal.

2. OPERATING CONDITIONS, OPERATING POSITION

Operating conditions

The actuators **MODACT MPS, MPSP (MODACT MPS, MPSP Control)** are resistant against influence of operating conditions and external effects of classes AC1, AD5, AD7, AE4, AE6, AF2, AG2, AH2, AK2, AL2, AM-2-2, AN2, AP3, BA4 and BC3 according to ČSN 33 2000-5-51 ed. 3.

When the actuator is installed on a free area it is recommended to fit it with a light shelter against direct impact of atmospheric effects. The shelter should overlap the actuator contour by at least 10 cm at the height of 20 – 30 cm.

When actuators are to be installed in the working environment with temperature below -10 °C and in the environment with relative humidity above 80 %, it is always necessary to use an anti-condensation heater fitted to all actuators.

The electric actuators can be installed in areas with non-flammable and non-conductive dust, provided that this does not adversely influence their function. Here, it is necessary to strictly observe ČSN 34 3205. It is recommended to remove dust as soon as its layer is about 1 mm thick.

Notes:

A sheltered location is considered a space where atmospheric precipitations are prevented from falling at an angle of up to 60° from the vertical.

The location of the electric motor should be such that cooling air has free access to the motor and no heated-up blown-out air is drawn in the motor again. For air inlet, the minimum distance from the wall is 40 mm. Therefore, the space in which the motor is located should be sufficiently large, clean and ventilated.

Temperature

Surrounding temperature for actuators **MODACT MPS (MPS CONTROL)**: from -25 °C to +70 °C and from -40 °C to +60 °C. Surrounding temperature for actuators **MODACT MPSP (MPSP CONTROL)**: from -25 °C to +60 °C and from -40 °C to +60 °C (*except 52 260*).

Classes of external influences – as extracted from ČSN 33 2000-5-51 ed. 3.

Class:

- 1) AC1 – above-sea level ≤ 2000 m
- 2) AD5 – spouting water; water may spout in all directions
AD7 – shallow immersion, possible sporadic partial or full coverage (*only MPSP*)
- 3) AE4 – slight dust formation
AE6 – strong dust formation (*only for MPSP type*)
- 4) AF2 – occurrence of corrosive or polluting agents is atmospheric; presence of corrosive pollutants is significant
- 5) AG2 – mean mechanical strain; in normal industrial operations
- 6) AH2 – mean vibrations; in normal industrial operations
- 7) AK2 – serious risk of plant and moulds growth
- 8) AL2 – serious risk of occurrence of animals (*insects, birds, small animals*)
- 9) AM-2-2 – normal level of signal voltage. No additional requirements.
- 10) AN2 – mean solar radiation. Intensity > 500 and ≤ 700 W / m².
- 11) AP3 – mean seismic impacts; acceleration > 300 Gal ≤ 600 Gal
- 12) BA4 – capability of persons; instructed persons
- 13) BC3 – frequent contact of persons with ground potential; persons often touch foreign conductive parts or stand on conductive substrate

The arctic version (*type no. 52 261-6.6xx0; 52 261-6.6xx9; 52 261-6.8xx0; 52 261-6.8xx9; 52 261-6.9xx0; 52 261-6.9xx9*) for surrounding temperature from -40 °C to +40 °C. The actuators in the arctic version should be resistant against impacts of operating conditions characterized by temperature in ranging from -40 °C to +40 °C and relative humidity from 5 % to 95 % at temperature +33 °C. These actuators will be designated with the letter F on the last place of the supplementary type number (*e.g. 52 261-6xx0F*).

Corrosion protection

Actuators are standardly delivered with surface treatment corresponding to category of corrosion aggressiveness C1, C2 and C3 according to ČSN EN ISO 12944-2.

On customer's request is possible to do surface treatment corresponding to category of corrosion aggressiveness C4, C5-I and C5-M.

In following table is provided an overview of environment for each categories of corrosion aggressiveness according to ČSN EN ISO 12944-2.

| Corrosion aggressiveness level | Example of typical environment | |
|---|---|---|
| | Outdoor | Indoor |
| C1 (very low) | | Heated buildings with clean atmosphere e.g. offices, shops, schools, hotels. |
| C2 (low) | Atmosphere with low level of pollution. Mostly outdoor areas. | Unheated buildings, in which may occur condensation, e.g. stocks, sports halls. |
| C3 (middle) | Urban industrial atmospheres, mild pollution of sulfur dioxide. Seaside areas with middle salinity. | Production areas with high humidity and low air pollution, e.g. food industry, processing factories, breweries. |
| C4 (high) | Industrial areas and seaside areas with middle salinity. | Chemical plants, swimming pools, seaside shipyard. |
| C5-I (very high – industrial) | Industrial areas with high humidity and aggressive atmosphere. | Buildings or areas with predominantly continuous condensation and high air pollution. |
| C5-M (very high – seaside) | Seaside areas with high salinity. | Buildings or areas with predominantly continuous condensation and high air pollution. |

Operating position

The actuators can be operated in any operating position.

3. OPERATION MODE, SERVICE LIFE OF ACTUATORS

Operation mode

The actuators can be operated with the type of loading S2 according to ČSN EN 60 034-1. The run period at temperature +50 °C is 10 minutes; the mean value of loading torque should not exceed 60 % of the value of maximum tripping torque M_V .

The actuators can also work in the regime S4 (*interrupted run with start-up*) according to ČSN EN 60 034-1. Load factor $N/(N+R)$ is max. 25 %; the longest working cycle ($N+R$) is 10 minutes (*course of working cycle is shown in the figure*). The highest number of closing operations in automatic regulation is 1200 cycles per hour. Mean value of loading torque with load factor 25 % and surrounding temperature +50 °C is not higher than 40 % of maximum tripping torque M_V .

The highest mean value of loading torque is equal to rated torque of the actuator.

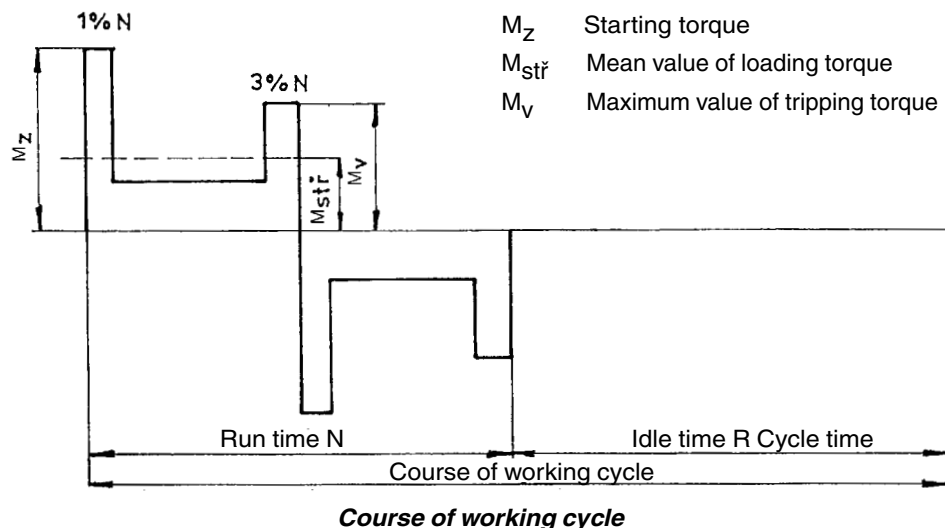

Service life of actuators

The actuator designed for shut-off valves must be able to perform at least 10,000 working cycles (*Close-Open -Close*).

The actuator designed for regulation purposes must be able to perform at least 1 million cycles with running time (*when the output shaft is moving*) at least 250 hours. Service life in operating hours (*h*) depends on loading and number of switching actions. High frequency of switching is not always beneficial for precision of regulation. For reaching the longest possible faultless period and service life, it is recommended to set frequency of switching to the lowest possible number of switching actions necessary for the given process. Orientational data of service life derived from the set regulation parameters are shown in the following table.

Service life of electric actuators for 1 million starts

| | | | | |
|------------------------|----------------------------|------|------|------|
| Service life [h] | 830 | 1000 | 2000 | 4000 |
| Number of starts [1/h] | max. number of starts 1200 | 1000 | 500 | 250 |

4. TECHNICAL DATA

Supply voltage

Rated value of alternating power supply voltage of the electric motor for the actuators is 3-phase 230/400 V, -15 % to +10 %, 50 Hz, the actuator type No. 52 260 equipped with electric motors 20 W, 60 W – 1 x 230 V, 50 Hz. Other supply voltage for electric actuators should be discussed with the manufacturer. The actuators **MODACT MPS**, **MPSP Control** 3 x 230/400 V, -15 % to +10 %, 50 Hz only.

Protective enclosure

Protection of the actuators **MODACT MPS (MODACT MPS Control)** is IP 55 according to ČSN EN 60 529.

Protection of the actuators **MODACT MPSP (MODACT MPSP Control)** is IP 67 (*except 52 260*) according to ČSN EN 60 529.

Noise

| | |
|------------------------------|----------------|
| Level of acoustic pressure A | max. 85 dB (A) |
| Level of acoustic output A | max. 95 dB (A) |

Tripping torque

At the factory, the tripping torque has been adjusted as shown in Table 1, according to the customer's requirements. If no tripping torque adjustment has been specified by the customer the maximum tripping torque is adjusted.

Self-locking

Self-locking is given by using a worm gear in the countershaft box.

Working stroke

The ranges of working stroke are given in Table No. 1.

Manual control

Manual control is performed by a hand wheel directly (*without a clutch*) and is also possible when the electric motor is running (*resulting motion of the output shaft is given by the differential gear function*). By rotating the hand wheel in the clock-wise direction the actuator output shaft rotates also in the clock-wise direction (*when viewing the shaft into the control box*). Provided that the valve nut has a left thread, the electric actuator closes the valve.

Torque-limit switches in the actuator are set and work when the actuator is under voltage.

When using the manual control, ie. actuator is controlled mechanically, the torque-limit switches doesn't work and the valve can be damaged.

5. ACTUATOR OUTFIT

Torque-limit switches

The actuator is fitted with two torque-limit switches MO, MZ (*type DB1G-A1LC*), each of which acts only in one direction of motion of the actuator output shaft. The torque-limit switches can be set to operate at any point of the working stroke. The tripping torque can be adjusted within the range shown in Table 1.

Position-limit switches

The PO, PZ position-limit switches limit the actuator working stroke, each being adjusted to operate in either end position
Actuators with resistive transmitter – type B 611, 2 pieces
Actuators type No. 52 260, actuators with current transmitter and actuators without transmitter – type DB1G-A1LC, 2 pieces

Position signalling

For signalling position of the actuator output shaft, two signalling switches, i.e. the SO, SZ signalling switch, each for one direction of movement of the output shaft are used. The operating point of the microswitches can be set within the whole working stroke range except the narrow band before the operating point of the microswitch used to switch off the electric motor.

Actuators type No. 52 260, actuators with current transmitter and actuators without transmitter – type DB1G-A1LC, 2 pieces

Position transmitters

The **MODACT MPS, MPSP** electric actuators can be supplied without position transmitter or can be fitted with position transmitter:

a) Resistance transmitter 1 x 100 Ω.

Technical parameters:

| | |
|-----------------------|------------|
| Position scanning | resistance |
| Turning angle | 0° – 320° |
| Non-linearity | ≤ 1 % |
| Transition resistance | max. 1,4 Ω |
| Permitted voltage | 50 V DC |
| Maximum current | 100 mA |

b) Type CPT 1Az passive current transmitter. Power supply to the current loop is not a part of the actuator. Recommended feeding voltage is 18 – 28 V DC, at maximum loading resistance of the loop 500 Ω. The current loop should be earthed in one point. Feeding voltage need not be stabilized; however, it must not exceed 30 V or else the transmitter could be damaged.

Range of CPT 1Az is set by a potentiometer on the transmitter body and its starting value by corresponding partial turning of the transmitter.

Technical parameters of CPT 1Az:

| | |
|--|---|
| Scanning of position | capacity |
| Working stroke | adjustable 0° – 40° to 0° – 120° |
| Non-linearity | ≤ 1 % |
| Non-linearity, including gears | ≤ 2,5 % (for a maximum stroke of 120°). |
| Hysteresis, including gears | ≤ 5 % (for a maximum stroke of 120°) |
| <i>(The non-linearity and hysteresis are related to a signal value of 20 mA)</i> | |
| Loading resistance | 0 – 500 Ω |
| Output signal | 4 – 20 mA or 20 – 4 mA |
| Supply voltage for R_{load} 0 – 100 Ω | 10 to 20 V DC |
| for R_{load} 400 – 500 Ω | 18 to 28 V DC |
| Maximum supply voltage ripple | 5 % |
| Maximum transmitter power demand | 560 mW |
| Insulation resistance | 20 MΩ at 50 V DC |
| Insulation strength | 50 V ss |
| Operational environment temperature | -25 °C to +60 °C |
| Operational environment temperature – extended range | -25 °C to +70 °C (Additional on demand) |
| Dimensions | ø 40 x 25 mm |

c) Type DCPT3 active current transmitter. Power supply to the current loop is not a part of the actuator. Maximum loading resistance of the loop is 500 Ω. For variants **MODACT MPS, MPSP Control** with the regulator ZP2.RE5, it is used as a position sensor.

DCPT3 can be easily set by two push-buttons with LED diode on the transmitter body.

Technical parameters of DCPT3:

| | |
|----------------------|--------------------------------|
| Scanning of position | contact-less magneto-resistant |
| Working stroke | adjustable 60° – 340° |
| Non-linearity | max. ±1 % |

| | |
|---------------------|------------------------|
| Loading resistance | 0 – 500 Ω |
| Output signal | 4 – 20 mA or 20 – 4 mA |
| Power supply | 15 – 28 V DC, < 42 mA |
| Working temperature | -25 °C to +70 °C |
| Dimensions | ø 40 x 25 mm |

For the transmitters CPT 1Az as well as DCPT3, a two-wire connection is used, i.e., the transmitter, the power supply and the load are connected in series. The user should secure that the two-wire circuit of the current transmitter is connected to the electric earth of the associated regulator, computer, etc. This connection should only be made at a single point in any section of the circuit, outside the actuator.

Anti-condensation heater

The actuators are fitted with an anti-condensation heater preventing condensation of water vapour. It is connected to the AC mains of voltage 230 V.

Local control

Local control serves for controlling the actuator from the site of its installation. It includes two change-over switches: one with positions “*Remote control – Off – Local control*”, the other “*Open – Stop – Close*”. The former change-over switch can be built-in as two-pole or four-pole. The change-over switches are installed in a terminal-board box and the control elements on the lid of this terminal-board box.

Position regulator

The position regulator built-in in the actuator enables to control position of the output shaft of the actuator and thus also the valve by the input analog signal.

The control unit is microprocessor-based programmed for regulating the actuator, ascertaining and repairing error conditions, and for simple setting of regulation parameters.

The regulator design enables to switch off the regulator feeding. If the regulator is not under voltage it does not regulate but, after its feeding is switched on, the regulator function is automatically restored; the parameters and diagnostic data stored in the regulator memory are retained.

The regulator circuits compare the input signal with the feedback signal from the position transmitter of the actuator output shaft. If there is a difference between the input and feedback signals the regulator closes one of the built-in contactors in the actuator so that the actuator shaft is reset to the position corresponding to magnitude of the input signal. When the feedback signal is equal to the input signal the actuator stops.

The control parameters are set by functional push-buttons on the regulator or by PC connected to the regulator via a serial interface for the period of setting the parameters or during the communication module.

Electro-dynamic brakes

It reduces the actuators run-down time from 0.5 – 1.3 s to 40 – 60 ms. This significant reduction in run-down time precise the control. When the actuator is in a standstill no braking moment is exerted

- BAM-002** it's the optional equipment of **MPS, MPSP Control** actuator without regulator
The brake operates autonomously and is run by auxiliary contact of the contactor.
- BR2** it's always part of **MPS, MPSP Control** actuator with regulator
The brake is interconnected with the regulator that provides impulse for action.

Switching of electric motor, contactor unit

The actuators in variants Control are fitted with built-in reversing contactor combinations. These are assembled of two contactors and an over-current relay. The combination also includes mechanical blocking that prevents both contactors from being closed at the same time. This could, for instance, happen in case of wrong connection of jumpers on the terminal board. The blocking is not dimensioned for long-term action. The over-current relays protects the electric motor against over-loading and is dimensioned with respect to its output. According to the actuator version, the contactors are controlled by the regulator, change-over switch of local control or external input. Control voltage is 230 V / 50 Hz as a standard; it is supplied via contacts of position and/or moment micro-switches. Thus, these micro-switches need not be led out of the actuator.

The contactors used have a long mechanical service life and great reserve in switching ability; consequently, the electric service life is also sufficient for particular use. The thermal relay is chosen so that it would reliably protect the electric motor against overload. Set-up and outfit of the actuators provide for simple connection to power-supply and control circuits.

The power-supply circuits can be common for the whole group of actuators, which will save the cabling.

6. ELECTRIC PARAMETERS

External electric connection

a) Actuator terminal board

The electric actuator is equipped with a terminal board for connection to external circuits. This terminal board uses screw terminals allowing conductors with a maximum cross-section 2,5 mm² to be connected. Access to the terminal board is obtained after removal of the terminal box cover. All control circuits of the electric actuator are brought out to the terminal board. The terminal box is fitted with cable bushings for connecting the electric actuator. The electric motor is fitted with an independent box with a terminal board and a bushing.

b) Connector

According to the customer's requirements the **MODACT MPS, MPSP** actuators can be fitted with the connector to provide for connection of control circuits. This connector uses screw terminals allowing conductors with a maximum cross-section 2,5 mm² to be connected. ZPA Pečky, a.s. also supplies a counterpart for the cable. In order to connect the cable to this counterpart it is necessary to use special crimping pliers.

Actuator internal wiring

The internal wiring diagrams of the **MODACT MPS, MPSP** actuators with terminal designation are shown in this Mounting instructions.

Each actuator is provided with its internal wiring diagram on the inner side of the terminal box. The terminals are marked on a self-adhesive label attached to a carrying strip under the terminal block.

Current rating and maximum voltage of microswitches

Maximum voltage of microswitches is 250 V AC as well as DC, at these maximum levels of currents.

| | |
|--------|----------------------------------|
| MO, MZ | 250 V AC / 2 A; 250 V DC / 0,2 A |
| SO, SZ | 250 V AC / 2 A; 250 V DC / 0,2 A |
| PO, PZ | 250 V AC / 2 A; 250 V DC / 0,2 A |

The microswitches can only be used as single-circuit devices. Two voltages of different values and phases cannot be connected to the terminals of the same microswitch.

Isolation resistance

Isolation resistance of electric control circuits against the frame and against each other is min. 20 MΩ. After dump test, isolation resistance of control circuits is min. 2 MΩ. Isolation resistance of the electric motor is min. 1,9 MΩ. See Technical specifications for more details.

Electric strength of electric circuits isolation

| | |
|--|--------------------------------------|
| Circuit of the resistance transmitter | 500 V, 50 Hz |
| Circuit of the current transmitter | 50 V DC |
| Circuits of microswitches and anti-condensation heater | 1 500 V, 50 Hz |
| Electric motor | Un = 1 x 230 V Un = 3 x 230/400 V |
| | 1 500 V, 50 Hz 1 800 V, 50 Hz |

Deviations of basic parameters

| | |
|-------------------|--|
| Tripping torque | ±15 % of the maximum range value |
| Adjusting speed | +10 % of the maximum range value -15 % of the rated value |
| Working stroke | 1 % |
| Angled lever play | max 1 % |

Protection

The control panel is connected to the protective terminal, which is located in the terminal box. During assembly is necessary to connected the protective terminal according to ČSN 33 2000-4-41. **MODACT MPS, MPSP Control** actuators have internal protective terminal in the electronic box.

If isn't the actuator equipment with overcurrent protection when purchased is needed to ensure that the protection is added externally.

7. DESCRIPTION AND FUNCTION

The lever actuators **MODACT MPS, MPSP** and **MODACT MPS, MPSP Control** are assembled of electric motor, countershaft box, power gearing, control box, and lever mechanism. The actuators include three-phase asynchronous motors attached to the countershaft box. The actuators, Type No. 52 260, include single-phase electric motors of 20 W and 60 W.

The countershaft box reduces the number of revolutions of the electric motor, self-locking of the whole actuator being provided by means of a self-locking worm gear drive. An advantage of this solution is that electric motors with an electromagnetic brake are not required.

The gears are centrally fitted on the output shaft, thus constituting an independent assembly group. The epicyclic gearing consists of a sun gear and three satellite gears in mesh with the internal gear ring of a double gear set. In its upper part, this double gear set has external teeth for the manual control worm. The worm shaft is spring-loaded, the axial force induced by the torque of the actuator output shaft moves the worm axially against the spring tension. The magnitude of torque is directly proportional to the length of worm advance motion.

The torque sensor acts depending on the length of worm stroke. The magnitude of torque is transmitted to the control box by means of a lever and a pin. The handwheel does not limit the axial motion of the worm and allows the actuator to be controlled in any operating condition, even if the motor is running.

Situated in the upper part of the actuator, the control box forms an independent assembly group. At its upper end, the output shaft of the actuator is extended to the control box.

The control box encloses the following functional units:

- a) Torque-limit switching unit
- b) Position-limit switching unit
- c) Resistance transmitter of 1 x 100 ohm, or the current transmitter of 4 to 20 mA with or without power supply
- d) Anti-condensation heater

The units listed in Point c) are supplied, according to the customer's order (*only one transmitter being always required*).

In addition, the **MODACT MPS, MPSP Control** actuators can be fitted with an electronic box housing the following instruments:

- a) Position regulator
- b) Reversing contactors of electric motor
- c) Electronic brake BAM for reducing the time of motor running-down
- d) Power supply transformer of 230 V / 24 V
- e) Alternatively, the electronic box can be fitted with a local control unit with the LOCAL-REMOTE switch and the OPEN-CLOSE-STOP switch
- f) Actuator terminal board

The individual design variants of the **MODACT MPS, MPSP Control** actuators are shown in the Table No. 1.

The **MODACT MPS, MPSP Control** actuator, together with the controlled device, form a position servo-loop. The operating conditions, the mechanical parameters and the electrical equipment of the control box are identical to those used by **MODACT MPS, MPSP** actuators.

A built-in position regulator, provides for automatic position adjustment of the output shaft, depending on the input signal of the regulator. The regulator output is formed by two relays that control the operation of the electric motor by means of two reversing contactors. Apart from its basic function, the regulator performs two auxiliary emergency functions whose activation can be selected. One of the functions permits the regulator to bring the output shaft into the OPEN or CLOSE position if the input or feedback signal has been lost. Or, the actuator remains in the position in which the loss of either signal occurred.

The other function enables the same effect to be obtained by interconnecting the regulator terminals 11 and 12 via an external contact. When the external contact has been broken the actuator operates again in a normal way. If this function is not required, no external contact is connected.

The auxiliary functions can only be effective at the input signals of 0 to 10 V or 4 to 20 mA.

The lever assembly is formed by a flange with a slot for fixing screws with stops. The flange is attached to the power gear unit. At its end, the output shaft has a put-on lever.

8. MODACT MPS, MPSP CONTROL ACTUATORS

The actuators **MODACT MPS, MPSP Control** may be equipped with an electronic position regulator. In conjunction with the valve having a suitable control characteristic, they constitute a position servo-loop. The output shaft of these actuators is automatically brought into the position corresponding to the input signal value of the regulator.

For application possibilities, operating conditions, technical parameters, a functional description, packaging and storing, functional tests and location of the instrument, attachment to a valve, adjustment of the actuator with the valve, operation and maintenance, failures and their removal, reference should be made to the part dealing with the **MODACT MPS, MPSP** actuators. This provision included therein also apply to the **MODACT MPS, MPSP Control** actuators. A survey of the **MODACT MPS, MPSP Control** actuators in current production is shown in Table 1.

The **MODACT MPS, MPSP Control** actuators may also be supplied with outlet shaft position control unit, thermal relay as motor overload protection, and electronic brake of asynchronous motor (*BAM-002 – actuators equipped with contactors only; BR2 – actuators with position control unit ZP.2RE5*).

All of the above instruments are housed in the contactor box which can be mounted instead of the terminal box of **MPS, MPSP** actuators. These actuators can also be supplied without position regulator and the BR2 electronic brake - see Table of design variants.

The connection of electric circuits of the control box to external circuits is carried out on the terminal board having additional terminals for connecting the voltage supply of 3 x 230/400 V, 50 Hz.

9. REGULATOR ZP2.RE5

The basic part of the regulator ZP2.RE5 is a microcomputer with control program, programmed in its internal memory. The microcomputer includes A/D converters for processing the control and feedback signal. The regulator provides for automatic setting of the actuator output shaft depending on the value of the current control signal. The regulator compares the value of the control signal with the value of the feedback signal from the position transmitter. In case a regulating deviation is found, the regulator activates the output signals FO or FZ controlling the actuator run until the output shaft is set into the position corresponding to the control signal value.

Note: *The regulator sets the position, however, it does not influence the rate of resetting. This is given by the type and version of the actuator.*

The regulator also monitors some process states and signalizes detected failures.

The regulator parameters can be set by the push-buttons SW1 and SW2, and/or by the computer with service program. The computer is connected via a communication module to the connector J7. The set parameters are stored in the memory of the EEPROM type, so that switching off of the feeding voltage does not damage the memory content.

The following parameters can be set by the regulator push-buttons:

- type of control signal
- response to the TEST signal and to an error detected by the regulator
- mirroring
- regulator insensitivity
- type of control

Other parameters can be set by PC. The computer can also be used for ascertaining diagnostic data on the regulator operation, e.g. the time for which the regulator has been in operation.

After setting the control parameters, during the so-called auto-calibration, the regulator is adjusted to the actuator and the valve it should control. The type of the feedback transmitter, end positions and inertia of the actuator output shaft are automatically detected and recorded into the regulator as parameters.

Error conditions detected by the regulator are signalized by LED diodes on the regulator. The regulator has an OK change-over contact, from which it is possible to lead out an error status signal. During a faultless operation and with the switched-off regulator, this contact is opened; during an error condition it is closed.

If PC is connected to the regulator the detected error is displayed on the computer. In case of an error, the regulator responds according to the set parameter “response to the signal TEST”.

Technical parameters of regulator

| | |
|---------------------------------|--------------------------------|
| Feeding voltage: | 230 V + 10 % -15 %, 50 – 60 Hz |
| Regulator linearity: | 0,5 % |
| Regulator insensitivity: | 1 – 10 % (<i>adjustable</i>) |

Input signals – double-value (N / 230 V):

| | |
|---------|---|
| UDRIVE | Control phase for outlets FO, FZ, protected by fuse F 1.6 A |
| TEST1,2 | Activation of regime TEST |
| MO, MZ | States of actuator limit switches |
| TP | Condition of motor thermal protection |

Input signals – analog:

| | |
|------------------|-------------------------------|
| Control signal: | 0/4 – 20 mA |
| Feedback signal: | Current transmitter 4 – 20 mA |

Output signals – double-value:

| | |
|----------|---|
| FO, FZ | Control phase, closing contacts of relay 5 A / 230 V |
| Relay OK | Signalization of failure, change-over contact 5 A / 230 V |
| BRAKE | Control signal for brake module (2 mA) |

Output signal – analog:

| | |
|---------------------------|---|
| Signalization of position | Galvanically isolated passive transmitter 0/4 – 20 mA, external feeding 15 – 30 V, load impedance max 500 ohm |
|---------------------------|---|

Signalization:

| | |
|-------------|---------------------------|
| D1 (yellow) | Setting / failure message |
| D2 (red) | Setting / failure message |
| D3 (green) | Feeding |
| D4 (green) | Drive opens |
| D4 (red) | Drive closes |

Error messages:

| |
|--|
| Regime TEST |
| Control signal missing (<i>only when signal 4 – 20 mA is used</i>) |
| Actuator was switched off by limit switch in other than limit position |
| Error of position sensor |
| Thermal protection of motor TP activated |
| Actuator is under local control |

Response to failure:

| | |
|-------------------------------|--|
| Regime TEST | Error message + actuator into position according to setting P2 |
| Error in control signal | Error message + actuator into position according to setting P2 |
| Error in position sensor | Error message + actuator stop |
| Failure of thermal protection | Error message + actuator stop |

Adjustable elements:

Communication connector (*for connection to PC*) 2x push-button for setting parameter without computer

Range of working temperatures:

-25 °C – +75 °C

Dimensions:

75 x 81 x 25 mm

10. ORDERING INFORMATION

When ordering, please specify the following:

- Number of actuators required
- Actuator designation
- Type number
- Working stroke (*maximum angle of lever displacement*)
- Adjusting time of the output section in seconds
- Supply voltage of electric motor
- Special requirements (*without transmitter, with resistance or current transmitter*)

Table 1 – MODACT MPS, MPSP, MODACT MPS, MPSP Control electric actuators
 – basic technical parameters, design variants

| BASIC OUTFIT: 1 electric motor 2 Torque-limit switches (OPEN and CLOSE) 2 Position-limit switches (OPEN and CLOSE) 2 Signalling switches (OPEN and CLOSE) (actuators t. no. 52 260, actuators with current transmitter and actuators without transmitter) 1 Anti-condensation heater | | | | | | | | | Additional Type No. | | |
|--|----------------------------|------------------------|-----------------|-------------|--|---|---|-----------------------|---|---------------------|-------------|
| Electrical connection | | | | | | | | | terminal board | | 6 x x x |
| | | | | | | | | | connector | | 7 x x x |
| | | | | | | | | | terminal board + local control unit | | 8 x x x |
| | | | | | | | | | connector + local control unit | | 9 x x x |
| TECHNICAL PARAMETERS | | | | | | | | | | | |
| Type designation | Tripping torque range [Nm] | Operating time [s/90°] | Motor power [W] | Voltage [V] | Motor current In [A] | Starting motor current [A] | Amount of lubricant [kg] | Weight [kg] | Type Number | | |
| | | | | | | | | | basic | additional | |
| MPS, 8/8 | 20 – 80 | 8 | 90 | 400 | 0,34 | 1 | 0,3 | 26 | 5 2 2 6 0 | x x 1 x | |
| MPS, 8/16 | | 16 | | | | | | | | x x 2 x | |
| MPS, 8/32 | | 32 | 60 | 230 | 0,53 | 1,15 | | | | x x 3 x | |
| MPS, 8/63 | | 63 | 20 | 230 | 0,4 | 1,63 | | | | x x 4 x | |
| MPS, 12,5/8 | 60 – 125 | 8 | 90 | 400 | 0,34 | 1 | 26 | 5 2 2 6 0 | x x 5 x | | |
| MPS, 12,5/16 | | 16 | | | | | | | x x 6 x | | |
| MPS, 12,5/32 | | 32 | 60 | 230 | 0,53 | 1,15 | | | x x 7 x | | |
| MPS, 12,5/63 | | 63 | 20 | 230 | 0,4 | 0,63 | | | x x 8 x | | |
| MPS, (MPSP) 16/16 | 100 – 160 | 16 | 120 | 400 | 0,42 | 1,44 | 0,5 | 5 2 2 6 1 | x x 1 x (P) | | |
| MPS, (MPSP) 16/32 | | 32 | | | | | | | x x 2 x (P) | | |
| MPS, (MPSP) 16/63 | | 63 | | | | | | | x x 3 x (P) | | |
| MPS, (MPSP) 16/120 | | 120 | | | | | | | x x 4 x (P) | | |
| MPS, (MPSP) 32/16 | 160 – 320 | 16 | 180 | 400 | 0,56 | 1,82 | 0,5 | 5 2 2 6 2 | x x 1 x (P) | | |
| MPS, (MPSP) 32/32 | | 32 | | | | | | | x x 2 x (P) | | |
| MPS, (MPSP) 32/63 | | 63 | | | | | | | x x 3 x (P) | | |
| MPS, (MPSP) 32/120 | | 120 | | | | | | | x x 4 x (P) | | |
| MPS, (MPSP) 63/16 | 320 – 630 | 16 | 370 | 400 | 1,03 | 3,25 | 0,7 | 5 2 2 6 3 | x x 1 x (P) | | |
| MPS, (MPSP) 63/32 | | 32 | | | | | | | x x 2 x (P) | | |
| MPS, (MPSP) 63/63 | | 63 | | | 180 | 400 | | | 0,56 | 1,82 | x x 3 x (P) |
| MPS, (MPSP) 63/120 | | 120 | | | x x 4 x (P) | | | | | | |
| MPS, (MPSP) 125/16 | 630 – 1250 | 16 | 370 | 400 | 1,03 | 3,25 | 0,7 | 5 2 2 6 4 | x x 1 x (P) | | |
| MPS, (MPSP) 125/32 | | 32 | | | | | | | x x 2 x (P) | | |
| MPS, (MPSP) 125/63 | | 63 | 180 | 400 | 0,56 | 1,82 | | | x x 3 x (P) | | |
| MPS, (MPSP) 125/120 | | 120 | x x 4 x (P) | | | | | | | | |
| MPS, (MPSP) 200/45 | 1250 – 2000 | 45 | 370 | 400 | 1,03 | 3,25 | 0,7 | 267 | 5 2 2 6 5 | x x 0 x (P) | |
| MPS, (MPSP) 400/45 | 2500 – 4000 | | | | | | | | 5 2 2 6 6 | x x 0 x (P) | |
| Notes: 1) Not available in Type No. 52 265 and 52 266. 2) Type No. 52 264 – 52 266 can be manufactured in IP 67. 10 th position of Type No. will be marked with letter P. | | | | | | Working stroke - mechanical connection with the controlled device | | with lever and flange | | 60° | x 1 x x |
| | | | | | | | | with stops | | 90° | x 2 x x |
| | | | | | | | | | | 120° | x 3 x x |
| | | | | | | | | 160° | x 4 x x | | |
| | | | | | | flanged design without lever and flange with stops 1) | | 60° | x 5 x x | | |
| | | | | | | | | 90° | x 6 x x | | |
| | | | | | | | | 120° | x 7 x x | | |
| | | | | | | | | 160° | x 8 x x | | |
| ATTACHMENTS | | | | | | | | | | | |
| MODACT MPS, MPSP actuators | | | | | | | | | | Additional Type No. | |
| Resistance transmitter 1 x 100 Ω | | | | | | | | | | x x x 1 | |
| Design without position transmitter | | | | | | | | | | x x x 0 | |
| Current position transmitter DCPT3 4 – 20 mA with built-in power supply unit | | | | | | | | | | x x x 7 | |
| Current position transmitter CPT 1Az 4 – 20 mA without built-in power supply unit | | | | | | | | | | x x x 9 | |
| ATTACHMENTS MODACT CONTROL MPS, MPSP actuators Type No. 52 261 - 52 266 LCU – local control unit | | | | | Letter in the last position of Type number | | | | | | |
| | | | | | Actuator design | | | | | | |
| | | | | | Complete with position regulator, brake and reversing contactors | | Without position regulator, with brake and reversing contactors | | Without position regulator and brake, with reversing contactors | | |
| with BMO | | without BMO | | with BMO | | without BMO | | with BMO | | without BMO | |
| Without position transmitter | | | | | | | | | | – | |
| Resistance transmitter 1 x 100 Ω | | | | | | | | | | – | |
| Current position transmitter DCPT3 4 – 20 mA with built-in power supply unit | | | | | | | | | | .xxxA | |
| Current position transmitter CPT 1Az 4 – 20 mA without built-in power supply unit | | | | | | | | | | – | |
| NOTE: The actuators MODACT MPS, MPSP Control with the regulator ZP2.RE5 – the digit 5 should be put at the 10 th place. | | | | | | | | | | | |
| 11th place: | | | | | | | | | | | |
| -25 °C to +70 °C | | | | | | | | | | no identification | |
| -40 °C to +60 °C | | | | | | | | | | F1 | |

MODACT MPS electric part-turn actuator, Type No. 52 260

– Design with terminal board

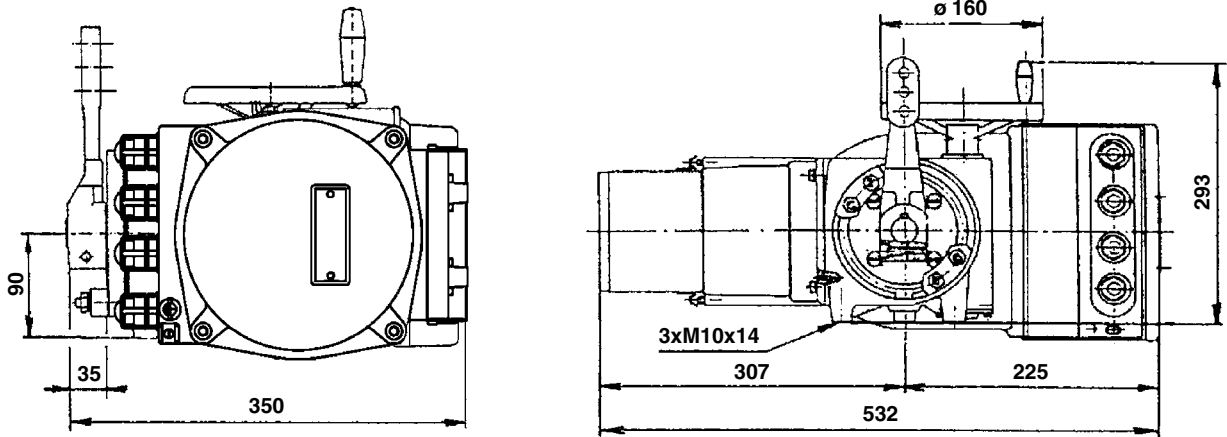

– Flanged design with terminal board

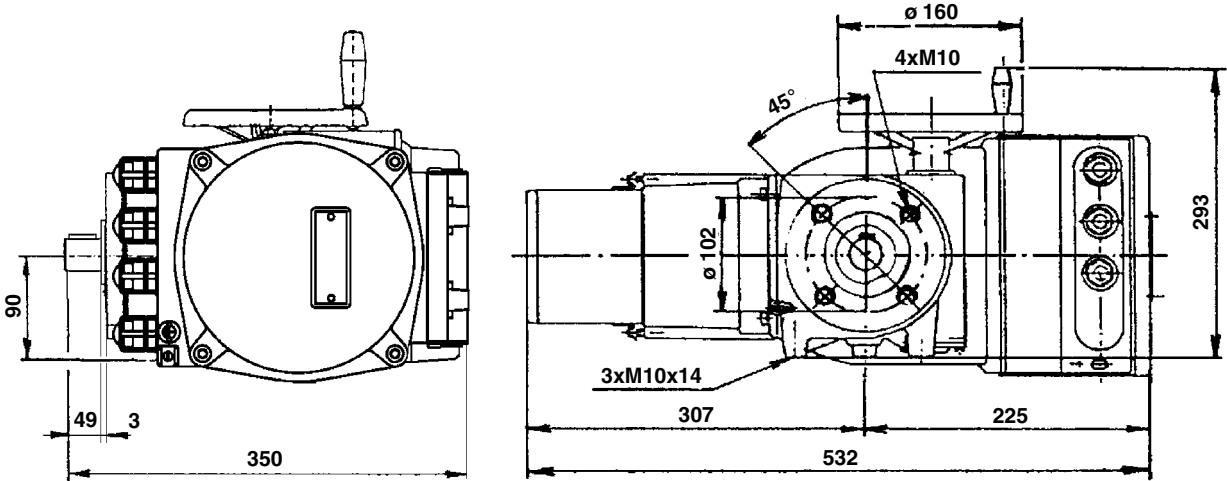

Note: Threads for cable bushings in the terminal box: 1 x M25 x 1.5, 3 x M20 x 1.5 (cable bushings are included – attached).

Lever

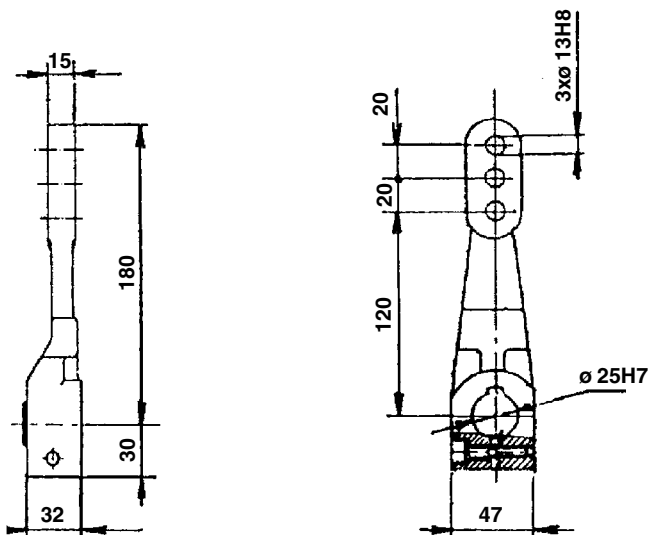

Mounting plate with holes

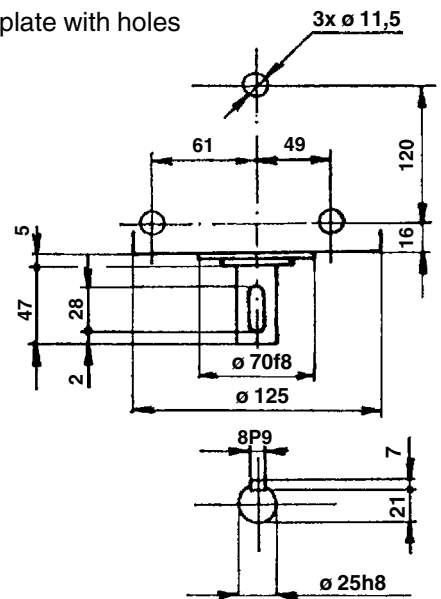

MODACT MPS, MPSP electric part-turn actuators, Type No. 52 261, 52 262

– Design with terminal board

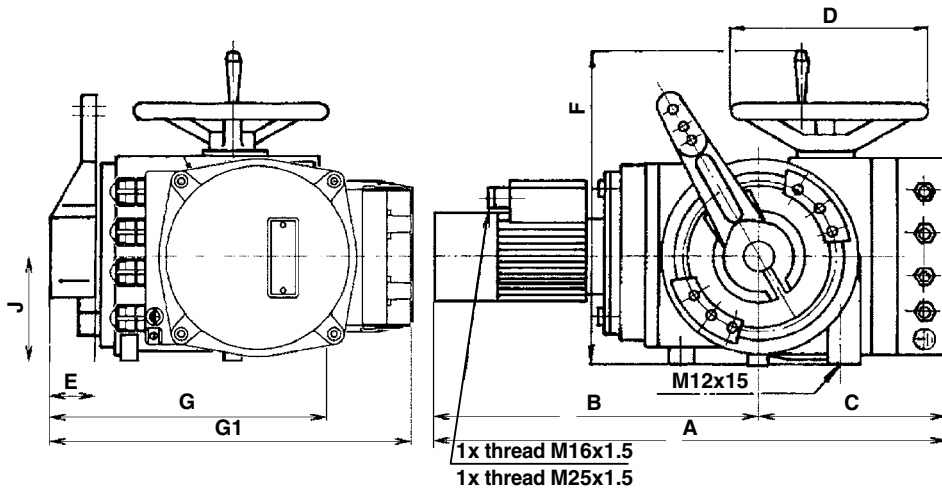

| | |
|----------------|--------------|
| A | 620 |
| B | 386 |
| C | 234 |
| D | ø 200 |
| E | 62 |
| E ₁ | 60 |
| F | 346 |
| G | 340 |
| G ₁ | 456 |
| J | 120 |
| K | 70 |
| L | 90 |
| M | 140 |
| N | 41 |
| O | ø 14 |
| P | 40 |
| R | 170 |
| S | 56 |
| T | 4 |
| U | 25 |
| X | 65 |
| Y | 41 |
| Z | 273 |
| d | ø 40 h 8 |
| d ₁ | ø 40 H 7 |
| d ₂ | 3 x ø 20 H 8 |
| b | 12 P9 |
| h | 8 |
| e | 35 |

– Flanged design with terminal board

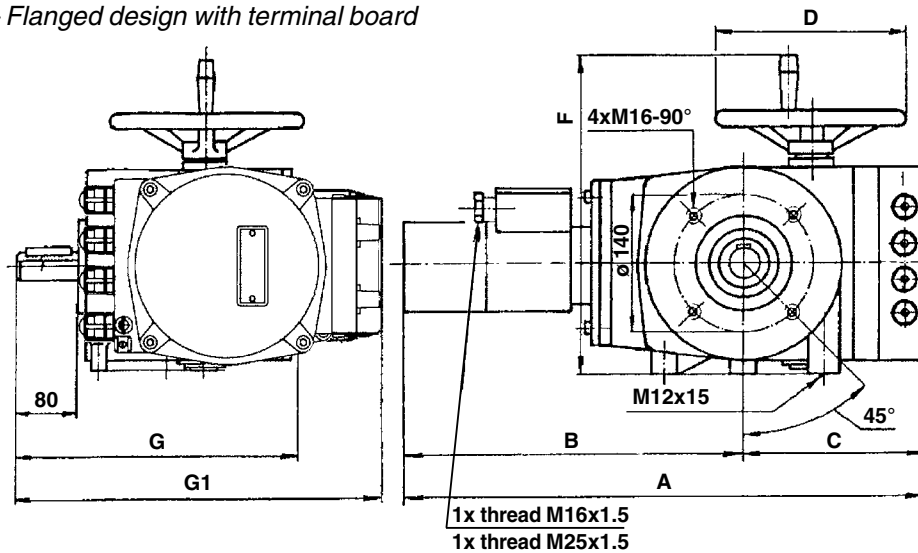

Note: Threads for cable bushings in the terminal box: 1 x M25 x 1.5, 3 x M20 x 1.5 (cable bushings are included – attached).

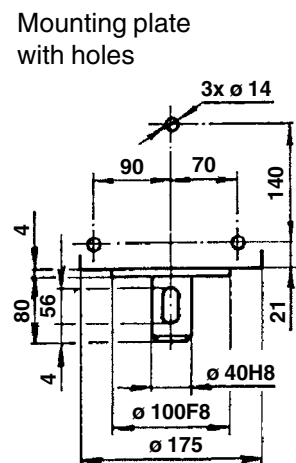
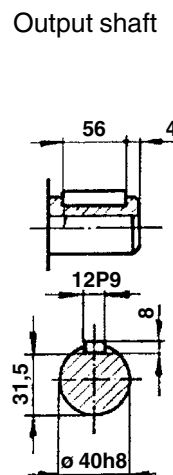
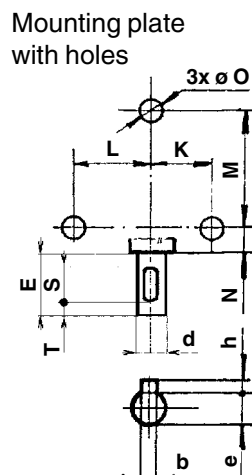
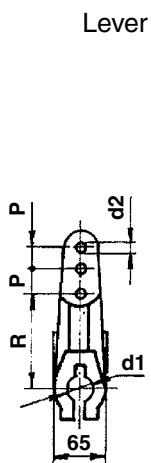

MODACT MPS, MPSP electric part-turn actuators, Type No. 52 263, 52 264

– Design with terminal board

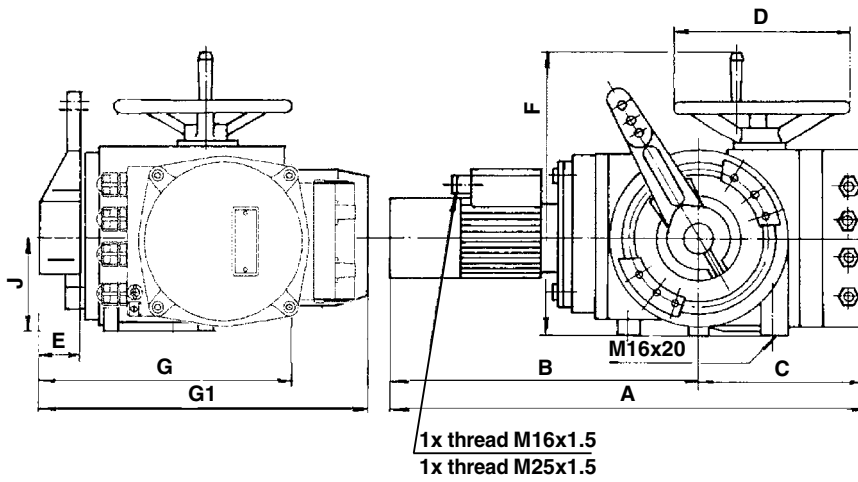

| | 52 263 | 52 264 |
|----------------|--------------|--------|
| A | 712 | 731 |
| B | 460 | 479 |
| C | 252 | |
| D | ø 250 | |
| E | 82 | |
| E ₁ | 80 | |
| F | 420 | |
| G | 445 | |
| G ₁ | 562 | |
| J | 145 | |
| K | 100 | |
| L | 110 | |
| M | 200 | |
| N | 60 | |
| O | ø 18 | |
| P | 40 | |
| R | 170 | |
| S | 70 | |
| T | 7 | |
| U | 30 | |
| X | 80 | |
| Y | 55 | |
| Z | 278 | |
| d | ø 50 h 8 | |
| d ₁ | ø 50 H 7 | |
| d ₂ | 3 x ø 25 H 8 | |
| b | 16 P9 | |
| h | 10 | |
| e | 43,8 | |

– Flanged design with terminal board

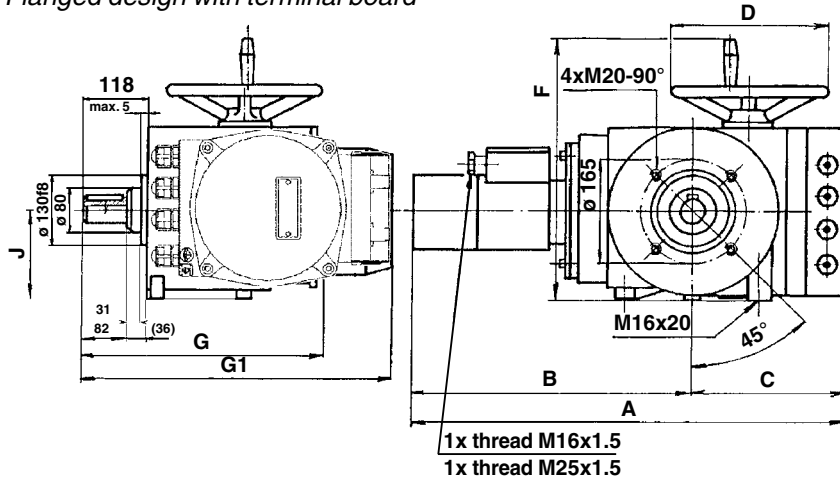

Note: Threads for cable bushings in the terminal box: 1 x M25 x 1.5, 3 x M20 x 1.5 (cable bushings are included – attached).

Lever

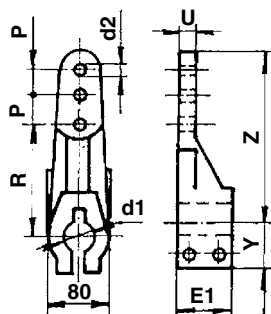

Mounting plate with holes

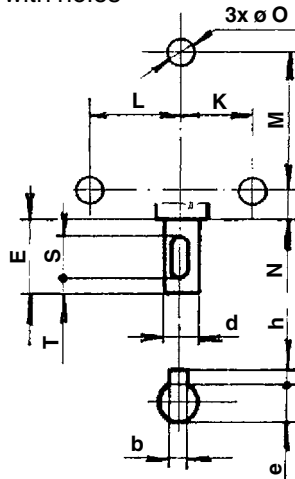

Output shaft

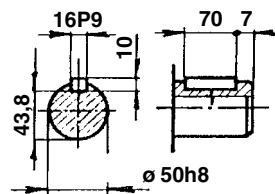

MODACT MPS, MPSP electric part-turn actuators, Type No. 52 265, 52 266

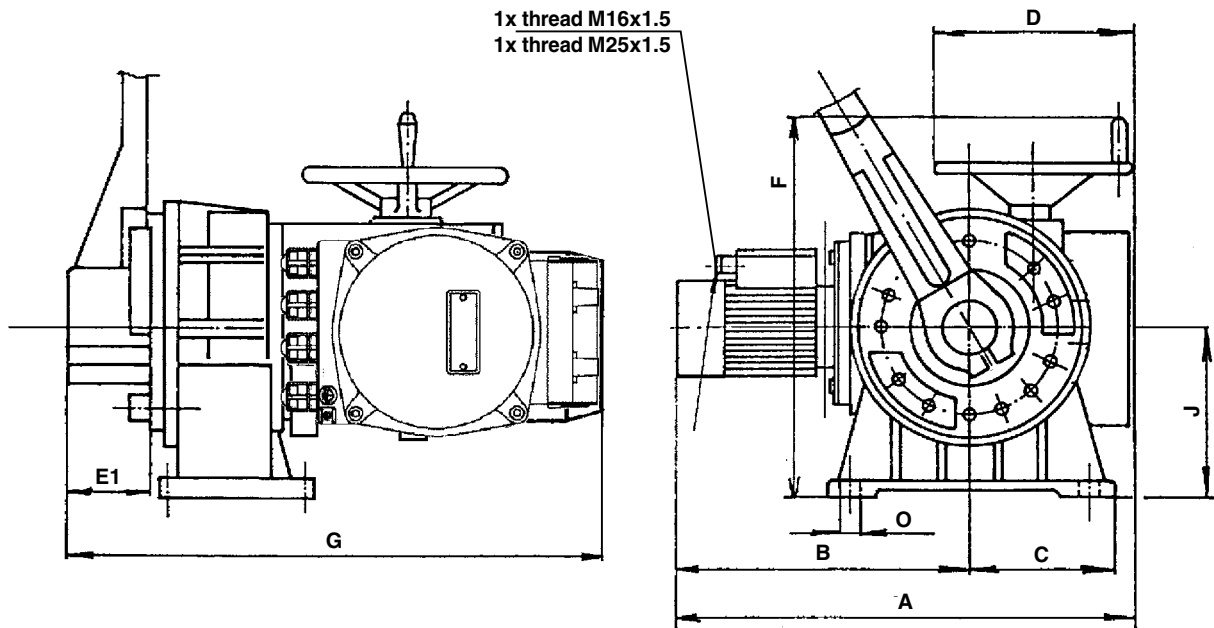

Note: Threads for cable bushings in the terminal box: 1 x M25 x 1.5, 3 x M20 x 1.5 (cable bushings are included – attached).

Mounting plate with holes

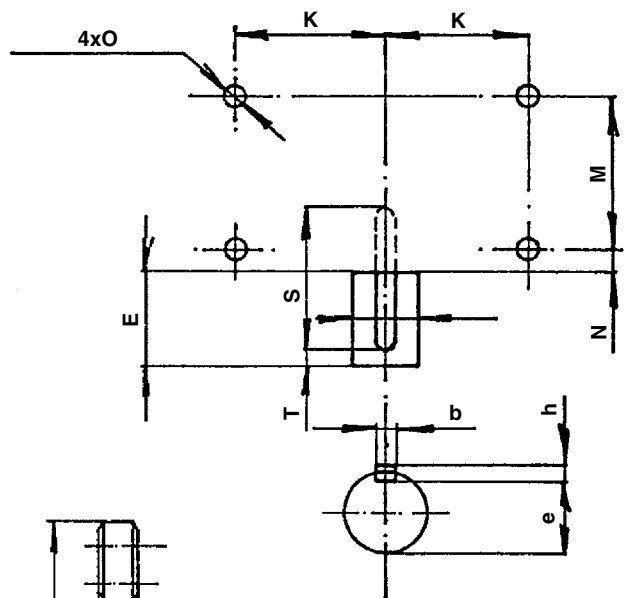

Lever

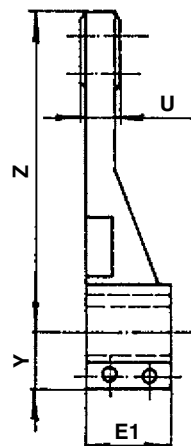
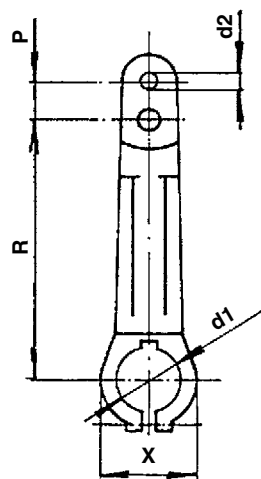

| | |
|----------------|---------|
| A | 743 |
| B | 498 |
| C | 220 |
| D | ∅ 300 |
| E | 123 |
| E ₁ | 120 |
| F | 560 |
| G | 760 |
| J | 260 |
| K | 185 |
| M | 200 |
| N | 33 |
| O | ∅ 22 |
| P | 55 |
| R | 400 |
| S | 180 |
| T | 11 |
| U | 36 |
| X | 130 |
| Y | 80 |
| Z | 490 |
| d | ∅ 90 h8 |
| d ₁ | ∅ 90 H7 |
| d ₂ | ∅ 40 H8 |
| b | 25 P9 |
| h | 14 |
| e | 81,3 |

Dimension drawing Pull Rod TV 360, Type No. 52 933 for actuators, **Type No. 52 260**

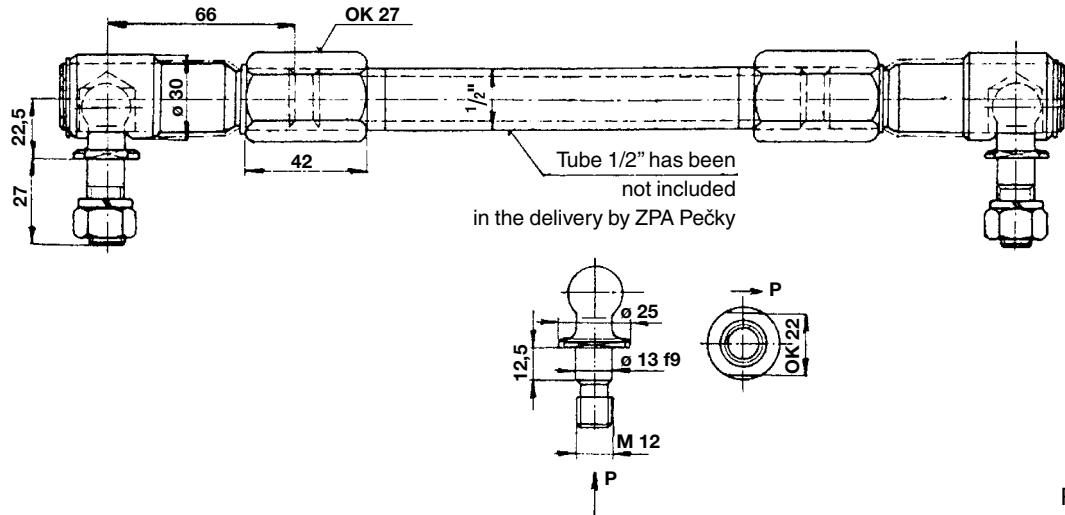

P-0210

Dimension drawing – Pull Rods TV 40 and TV 50

Actuator side Design TV 40-1/20 - Type No. 52 927 Controlled device side
TV 50-1/25 - Type No. 52 929

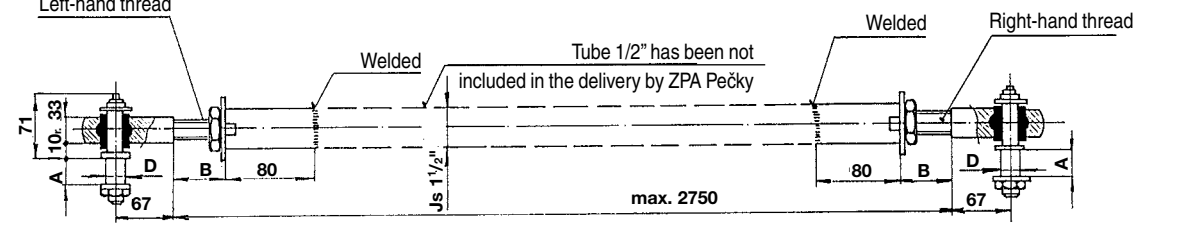

| Type | Type No. | Dimensions | | | | Designed for actuator, Type No. |
|--------------|----------|------------|---------------------|----|--------------------|---------------------------------|
| | | ø D j7 | ø D ₁ j7 | A | B | |
| TV 40 - 1/20 | 52 927 | 20 | - | 23 | min. 30 max. 50 | 52 261 |
| TV 40 - 2/25 | 52 928 | | 25 | | | 52 262 |
| TV 50 - 1/25 | 52 929 | 25 | - | 28 | | 52 263 |
| TV 50 - 2/25 | 52 930 | | 25 | | | 52 264 |

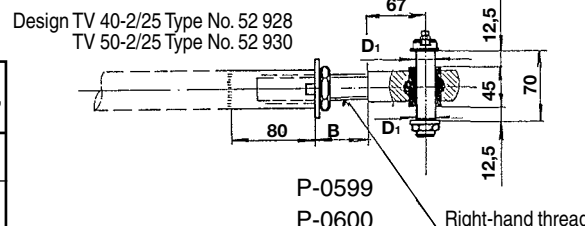

Dimension drawing – Pull Rod TV 90

Actuator side Welded Tube 1/2" has been not Welded Controlled device side
included in the delivery by
ZPA Pečky

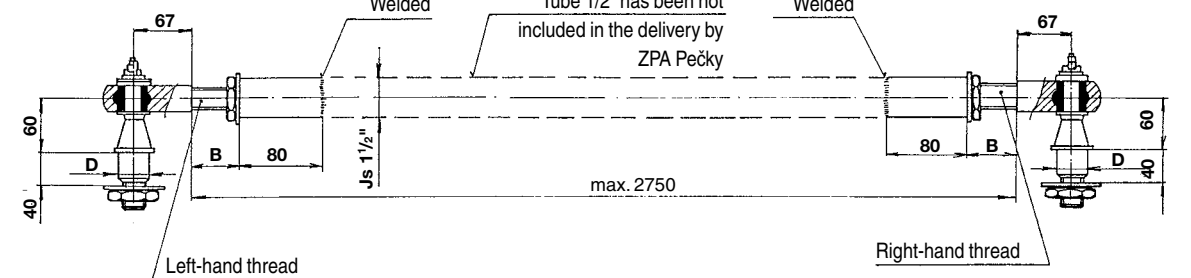

| Type | Type No. | Dimensions | | | | Designed for actuator, Type No. |
|--------------|----------|------------|---------------------|------|--------------------|---------------------------------|
| | | ø D j7 | ø D ₁ j7 | A | B | |
| TV 90 - 1/40 | 52 934 | 40 | - | - | min. 20 max. 50 | 52 265 |
| TV 90 - 2/25 | 52 935 | | 25 | 12,5 | | 52 266 |

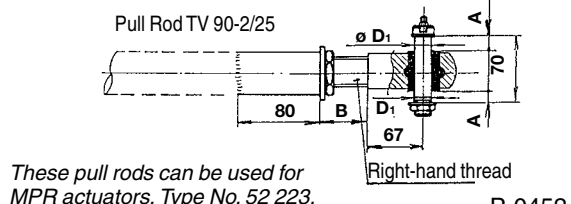

P-0452

Designed for connecting the actuators to the controlled device, these pull rods provide for the transmission of movements of the output section of the actuators to the controlled device. Not included in the delivery, they should be ordered separately.

Internal wiring diagrams of **MODACT MPS, MPSP** electric part-turn actuators

Legend:

- SQ1 (MO) – OPEN torque-limit switch
- SQ2 (MZ) – CLOSE torque-limit switch
- SQ3 (PO) – OPEN limit switch
- SQ4 (PZ) – CLOSE limit switch
- SQ5 (SO) – OPEN signalling switch
- SQ6 (SZ) – CLOSE signalling switch
- BMO – block of local control (LCU)
- SA1 (M/D) – LOCAL/0/REMOTE control switch
- SA2 (O/Z) – OPEN/0/CLOSE switch
- BQ1, BQ2 (V1, V2) – potentiometer 1 x 100 Ω (V1, V2)

- CPT 1Az – current position transmitter, analogue adjustable
- DCPT3 – current position transmitter, digitally adjustable
- DCPZ – power supply for DCPT3
- EH – anti-condensation heater
- C – capacitor
- F – overcurrent protection of electric motor
- FT – filter of supply voltage
- MS – terminal board for electric motor connecting
- M1~ – one-phase asynchronous motor
- M3~ – three-phase asynchronous motor

Selectors positions: M – local control; D – remote control; Z, CLOSE – closed; O, OPEN – open

List of wiring diagrams:

| MPS 52 260 – 52 266 | with terminal board | | with connector | |
|---------------------|---------------------|----------|----------------|----------|
| | – | BMO | – | BMO |
| MPS, MPSP | P3M-0946 | | P3M-0952 | |
| MPS, MPSP Control | P3-0947 | P3M-0948 | P3-0953 | P3M-0954 |
| MPS, MPSP, ZP2.RE5 | P3-0949 | P3M-0950 | P3-0955 | P3M-0956 |

Wiring diagram of electric actuators **MODACT MPS,** **T. No. 52 260 and 52 261 - 6**

– with terminal board

P3M-0946

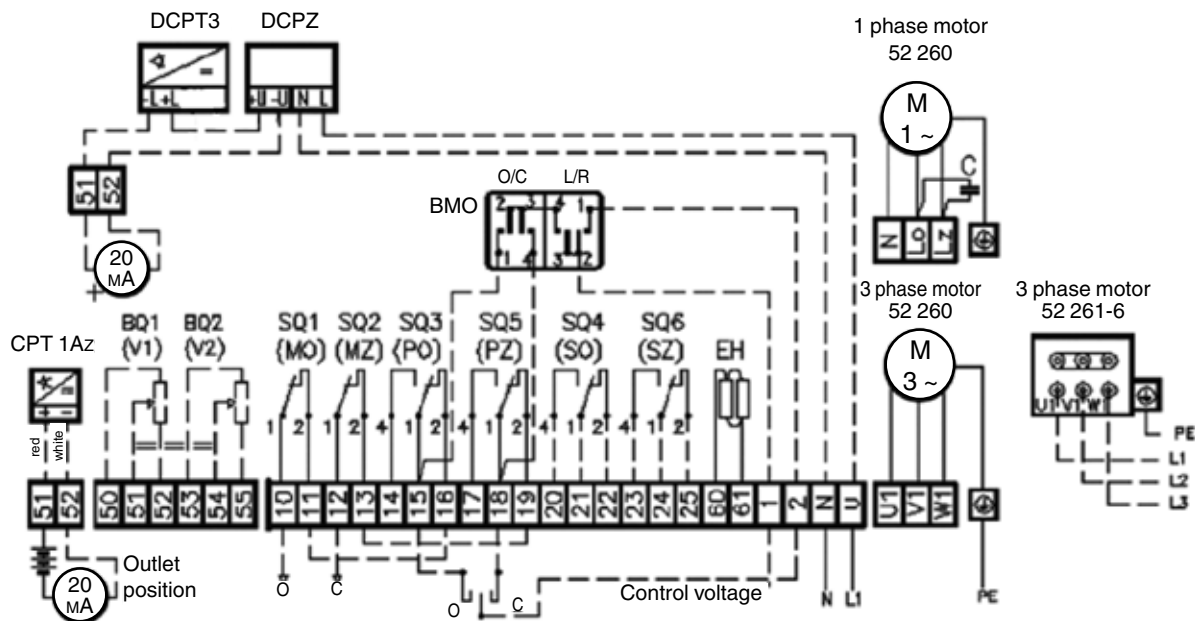

Wiring diagram of electric actuators **MODACT MPS, MPSP Control**

– with contactors

– with terminal board

P3-0947

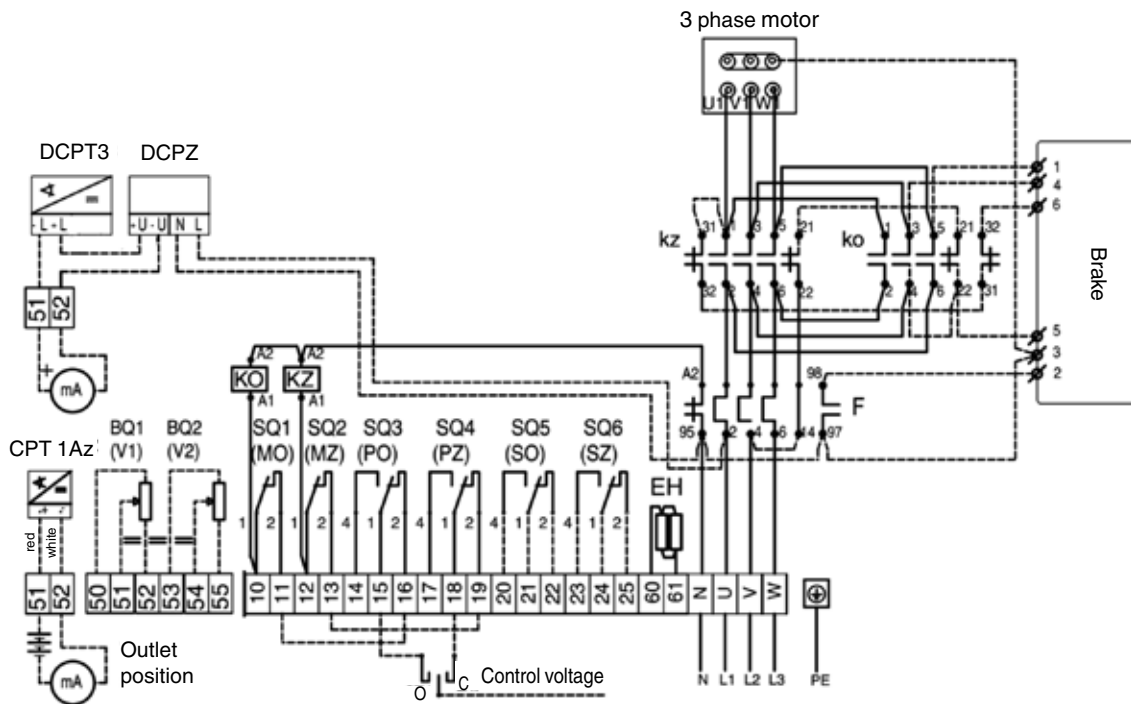

Wiring diagram of electric actuators **MODACT MPS Control**

– with contactors and BMO

– with terminal board

P3M-0948

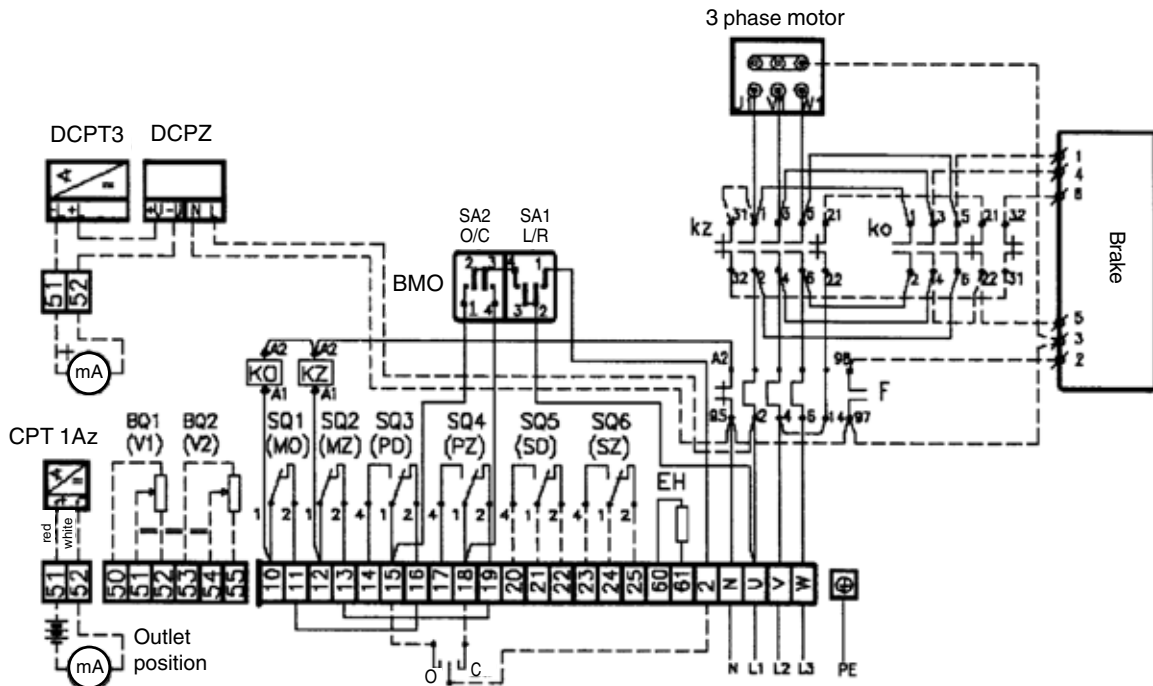

Wiring diagram of electric actuators **MODACT MPS, MPSP Control, T. No. 52 261- 6,**

– with contactors and regulator ZP2.RE5

– with terminal board

P3-0949

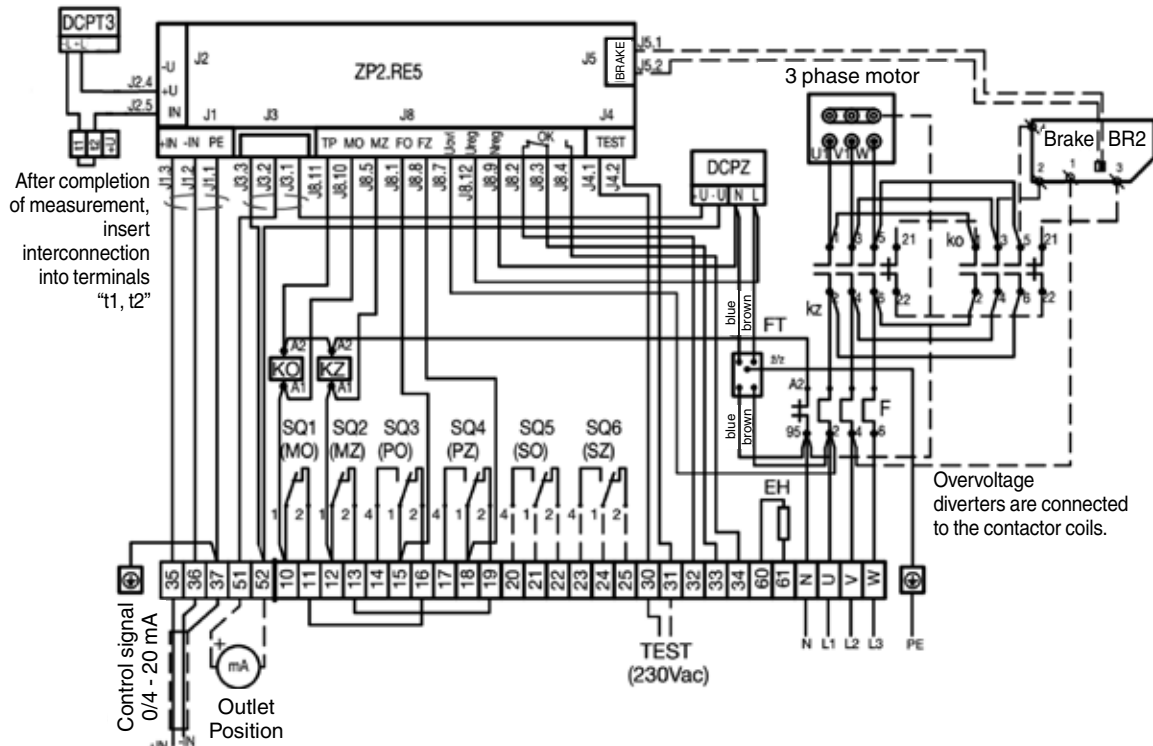

Wiring diagram of electric actuators **MODACT MPS, MPSP Control, T. No. 52 261- 6**

– with contactors, with regulator ZP2.RE5 and BMO

– with terminal board

P3M-0950

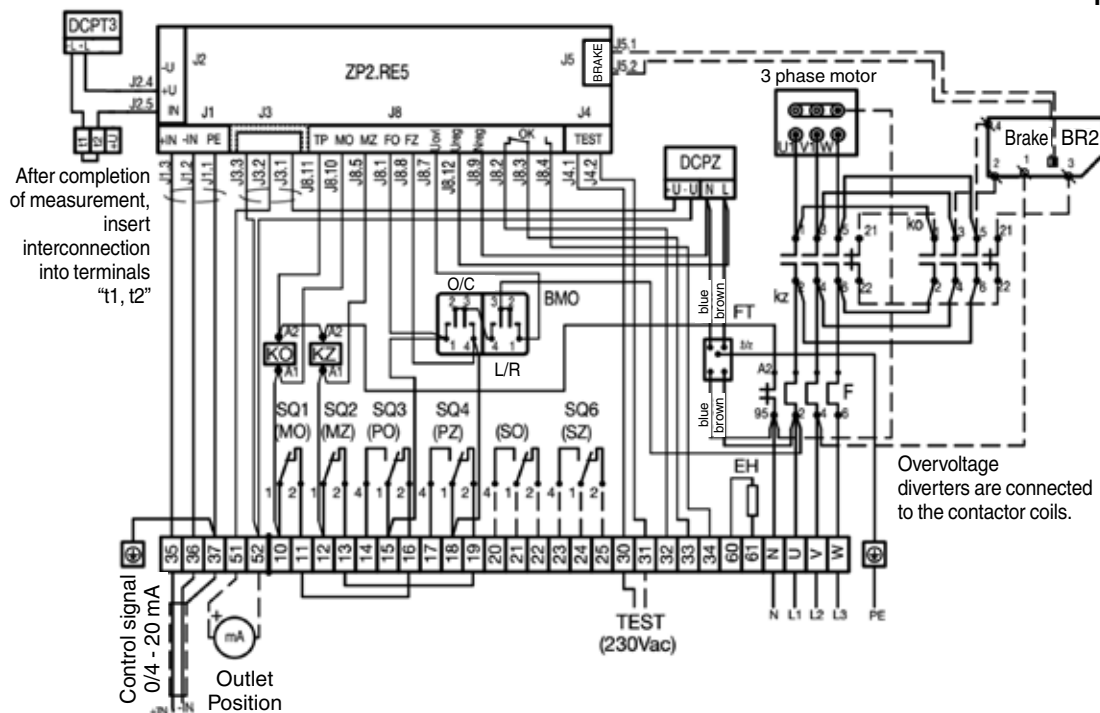

Connector

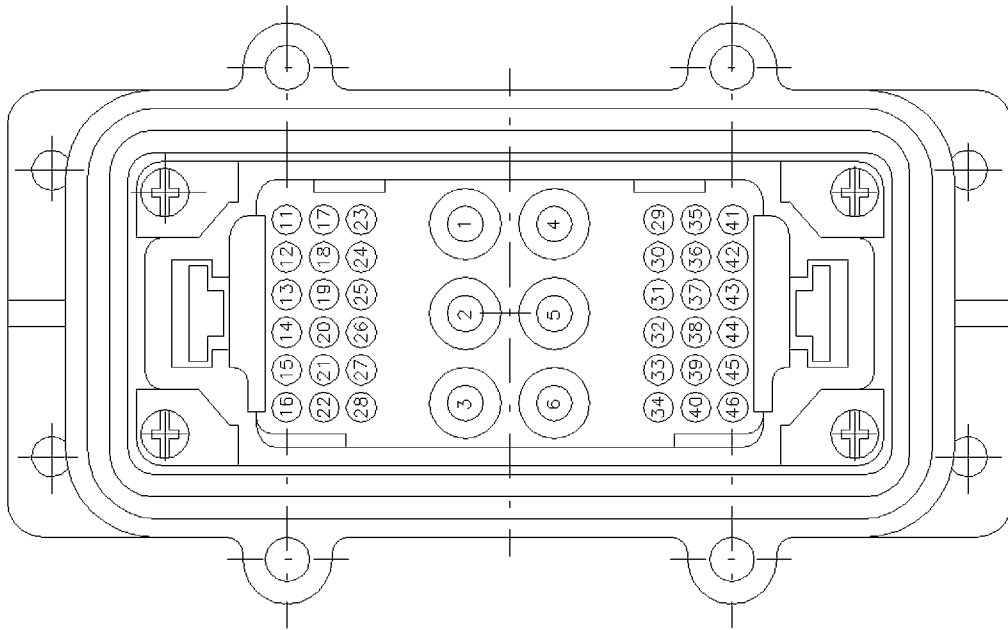

Wiring diagram of electric actuators **MODACT MPS, MPSP** T. No. 52 260 and 52 261-6

– with connector

P3M-0952

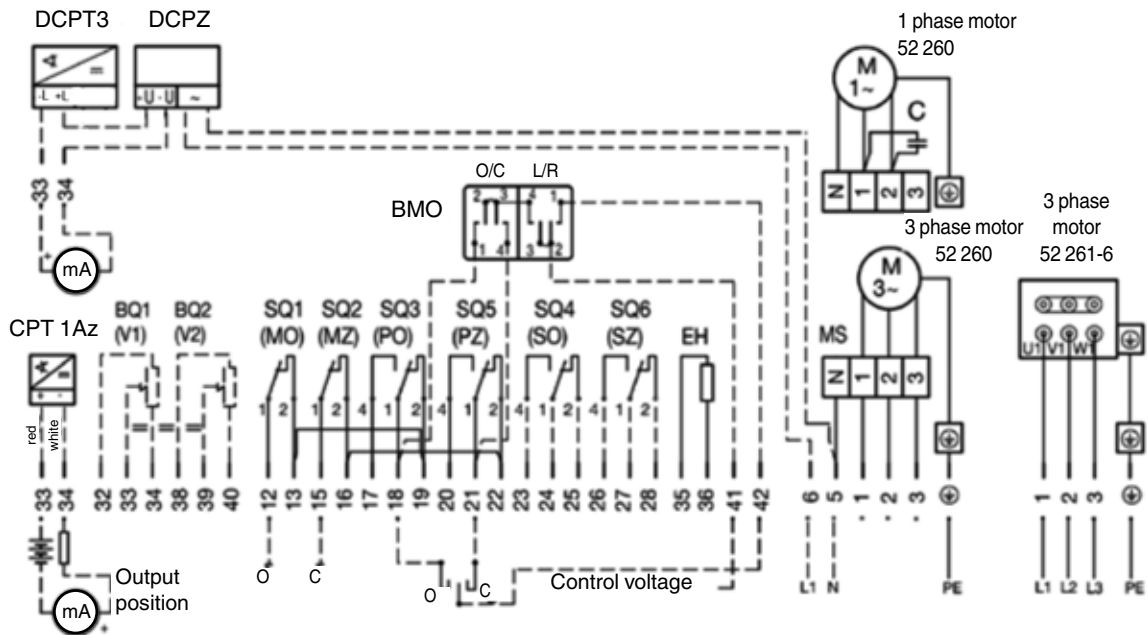

Wiring diagram of electric actuators **MODACT MPS, MPSP Control**

– with contactors

– with connector

P3-0953

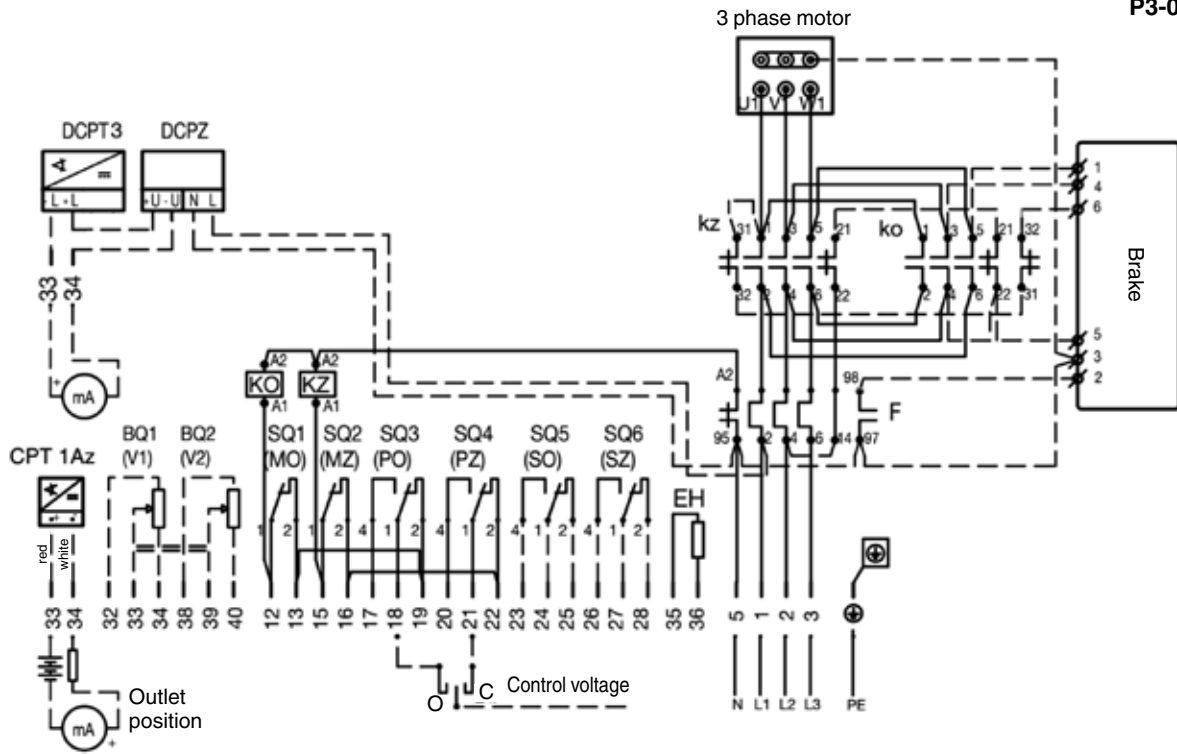

Wiring diagram of electric actuators **MODACT MPS, MPSP Control**

– with contactors and BMO

– with connector

P3M-0954

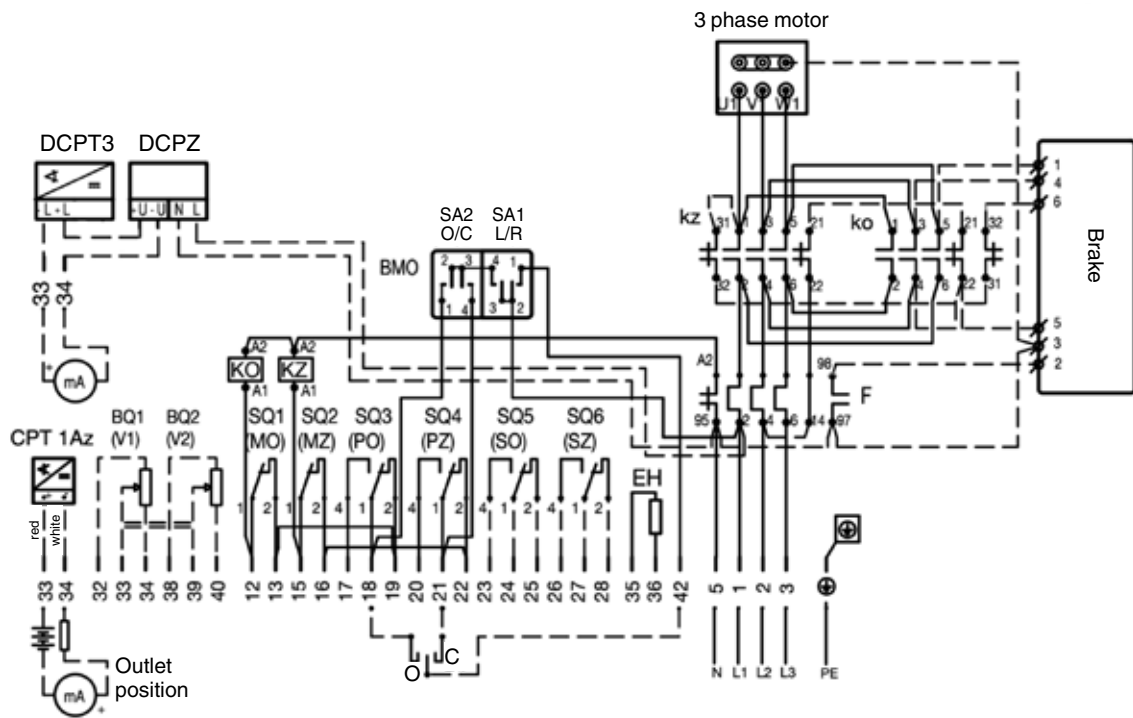

Wiring diagram of electric actuators **MODACT MPS, MPSP Control, T. No. 52 261- 6,**
 – with contactors, with regulator ZP2.RE5

– with connector

P3-0955

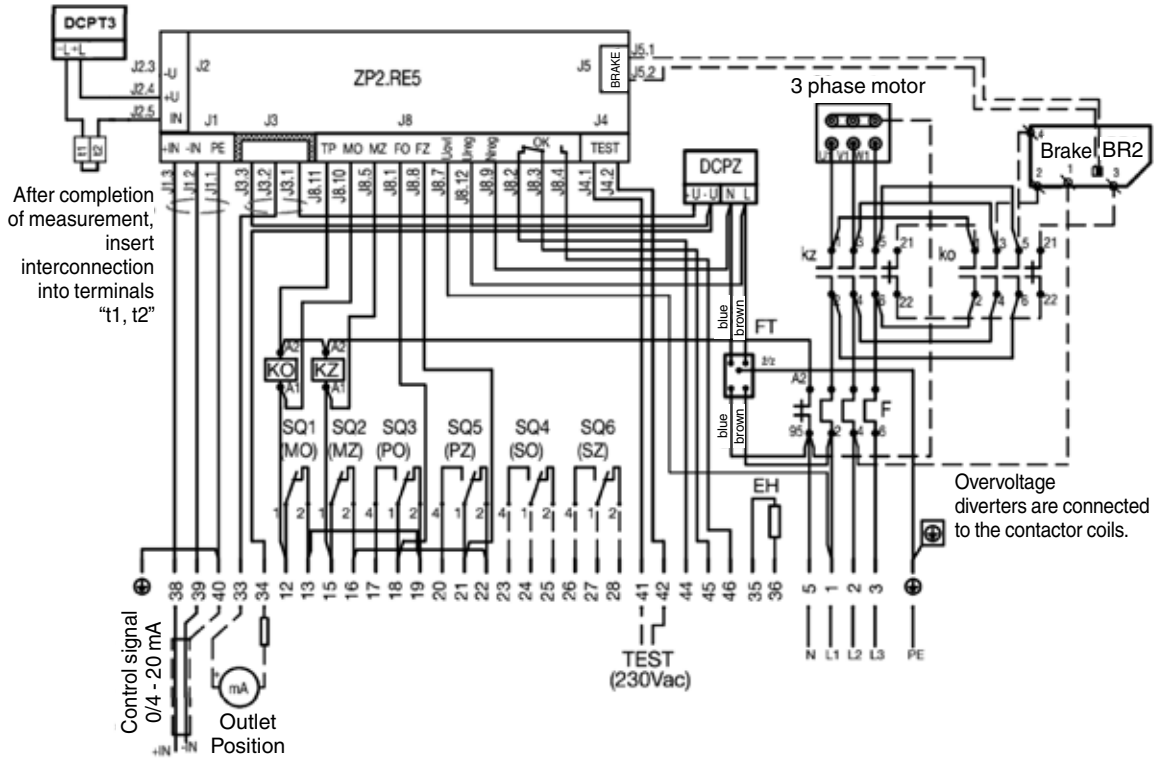

Wiring diagram of electric actuators **MODACT MPS, MPSP Control, T. No. 52 261- 6,**
 – with contactors, with BMO and regulator ZP2.RE5

– with connector

P3M-0956

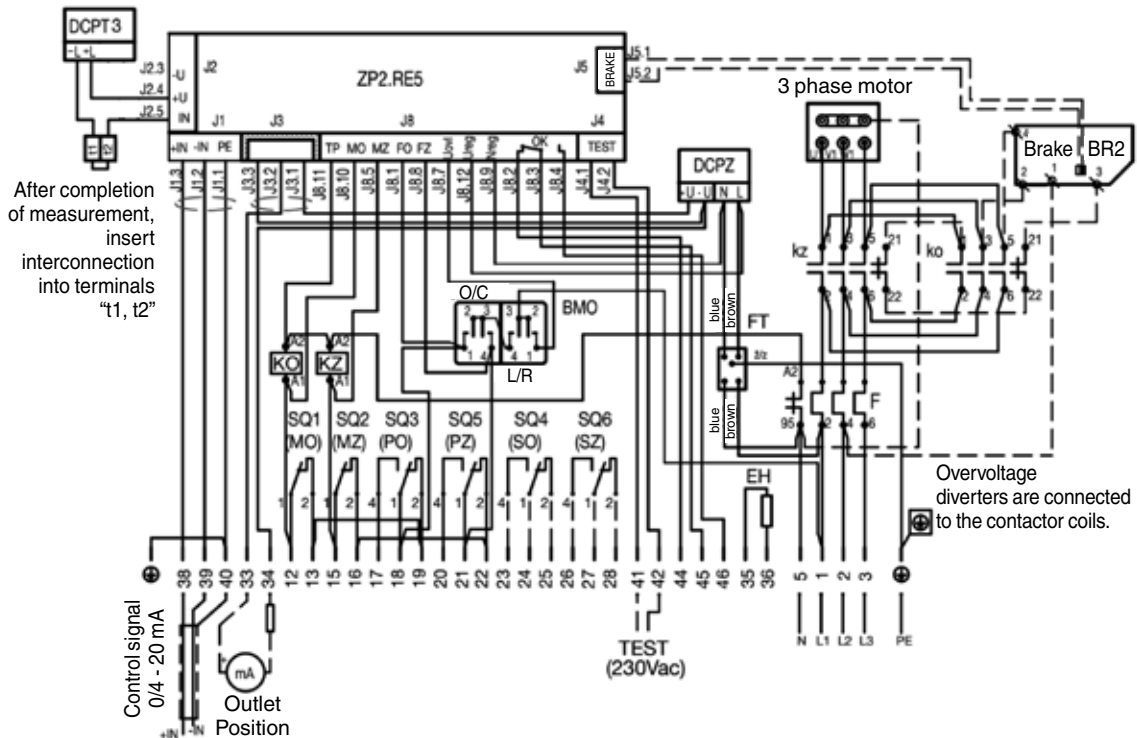

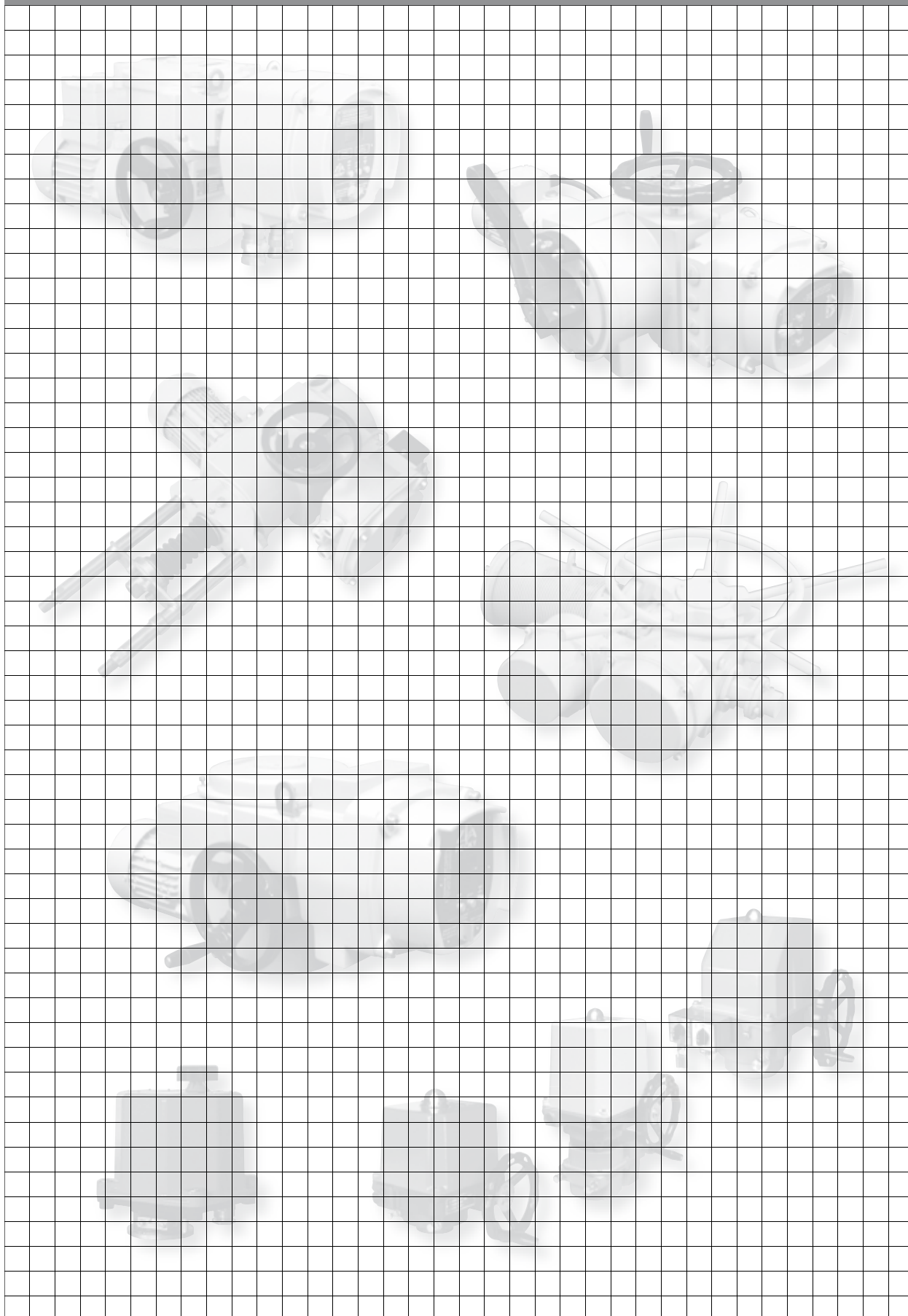

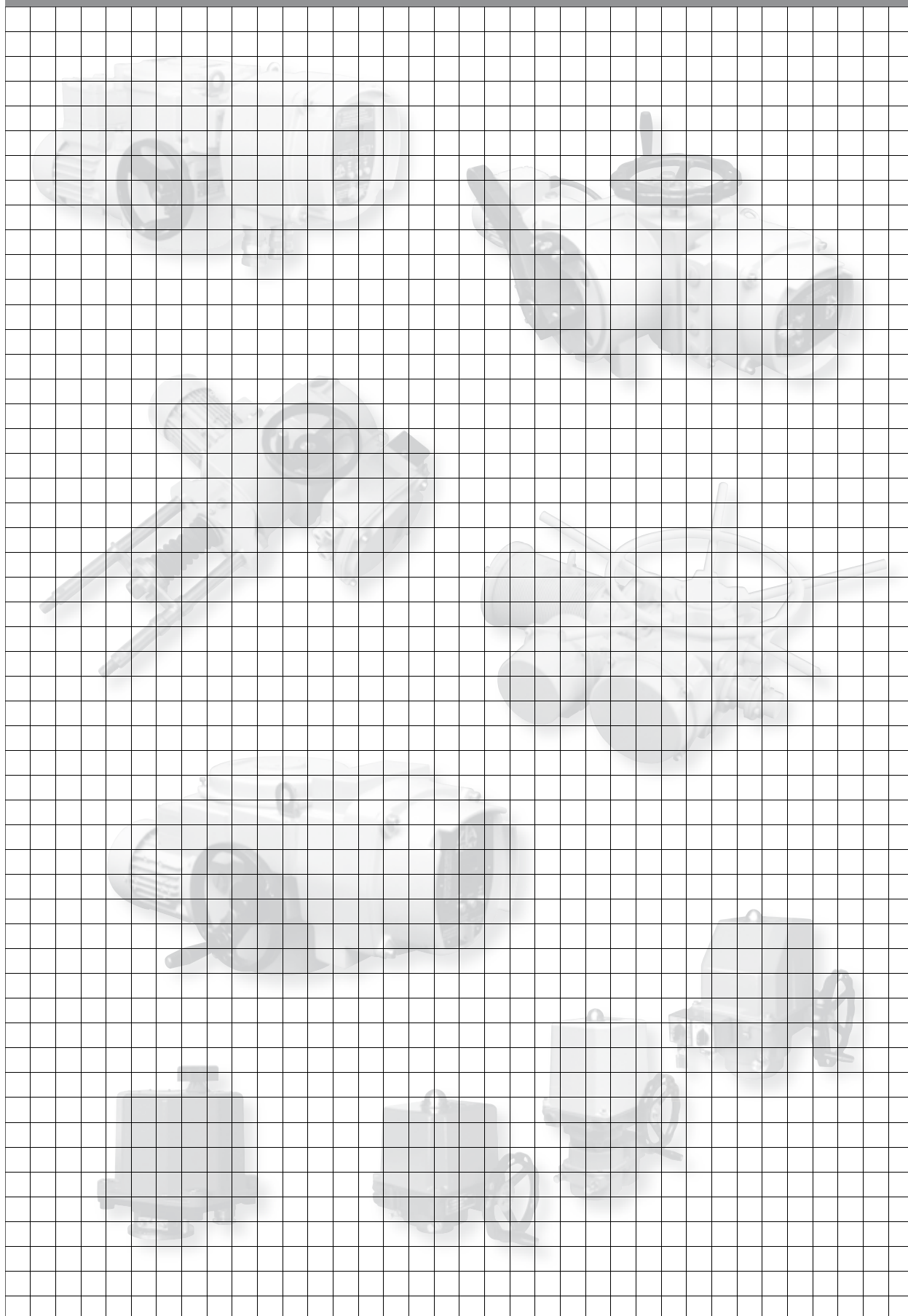



Development, production and services of electric actuators and switchboards.
Top-quality sheet-metal processing (TRUMPF equipment), powder paint shop.

SURVEY OF PRODUCED ACTUATORS

KP MINI, KP MIDI

Electric rotary (90°) actuators (up to 30 Nm)

MODACT MOK, MOKED, MOKP Ex, MOKPED Ex

Electric rotary (90°) actuators for ball valves and flaps

MODACT MOKA

Electric rotary (90°) actuators for nuclear power stations application outside containment

MODACT MON, MOP, MONJ, MONED, MOPED, MONEDJ

Electric rotary multi-turn actuators

MODACT MO EEX, MOED EEX

Explosion proof electric multi-turn actuators

MODACT MOA

Electric multi-turn actuators for nuclear power stations application outside containment

MODACT MOA OC

Electric multi-turn actuators for nuclear power stations application inside containment

MODACT MPR VARIANT

Electric rotary (160°) lever actuators with a variable output speed

MODACT MPS KONSTANT, MPSED

Electric rotary (160°) lever actuators with a constant output speed

MODACT MTN, MTP, MTNED, MTPED

Electric linear thrust actuators with a constant output speed

Deliveries of assembled actuator + valve (or MASTERGEAR gearbox) combinations

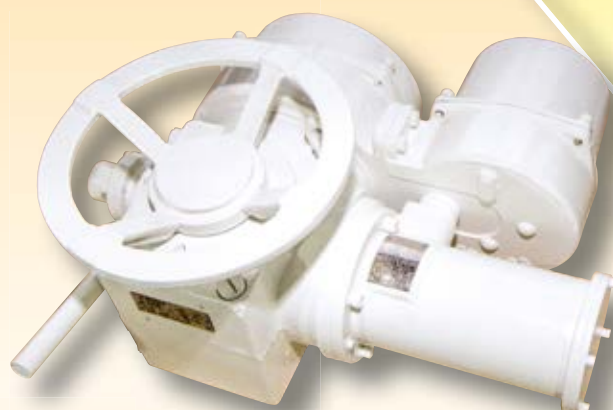

ZPA Pečky, a.s.
tř. 5. května 166
289 11 PEČKY, Czech Republic
www.zpa-pecky.cz

tel.: +420 321 785 141-9
fax: +420 321 785 165
+420 321 785 167
e-mail: zpa@zpa-pecky.cz